



Multi-functional Flow Control Valve for Water Treatment Systems

F135A (17610T)

WENZHOU RUNXIN MANUFACTURING MACHINE CO., LTD.

ADD: NO.169, RUNXIN ROAD, SHANFU TOWN, WENZHOU, ZHEJIANG, CHINA.

Tel: 0086-577-88630038, 88576512, 85956057 Fax: 0086-577-88633258

<http://www.run-xin.com> Email:sales@run-xin.com

Rev.A. 2012

User Manual



Please read this manual in details
before using this valve and keep it properly
in order to consult in the future

0WRX.466.748

Catalogue

1.Product Structure and Technical Parameters.....	2
2.Installation.....	3
A.Installation notice.....	3
B.Device location.....	3
C.Install control valve.....	3
D.Connect U1 valve and U2 valve.....	4
E.Install flow meter and drain connector.....	4
F.Pipeline connection.....	5
3.System Configuration and Flow Rate Curve.....	6
A.Product Configuration.....	6
B.Flow Rate Characteristic.....	6
4.Basic Setting & Usage.....	7
5.Assembly & Parts.....	8
6.Warranty Card.....	11

● If there is no special requirement when product purchase, we choose 4# injector without drain line flow control for the F135 standard configuration.

MODEL: F135A(17610T)

1.Product Structure and Technical Parameters (17610T)

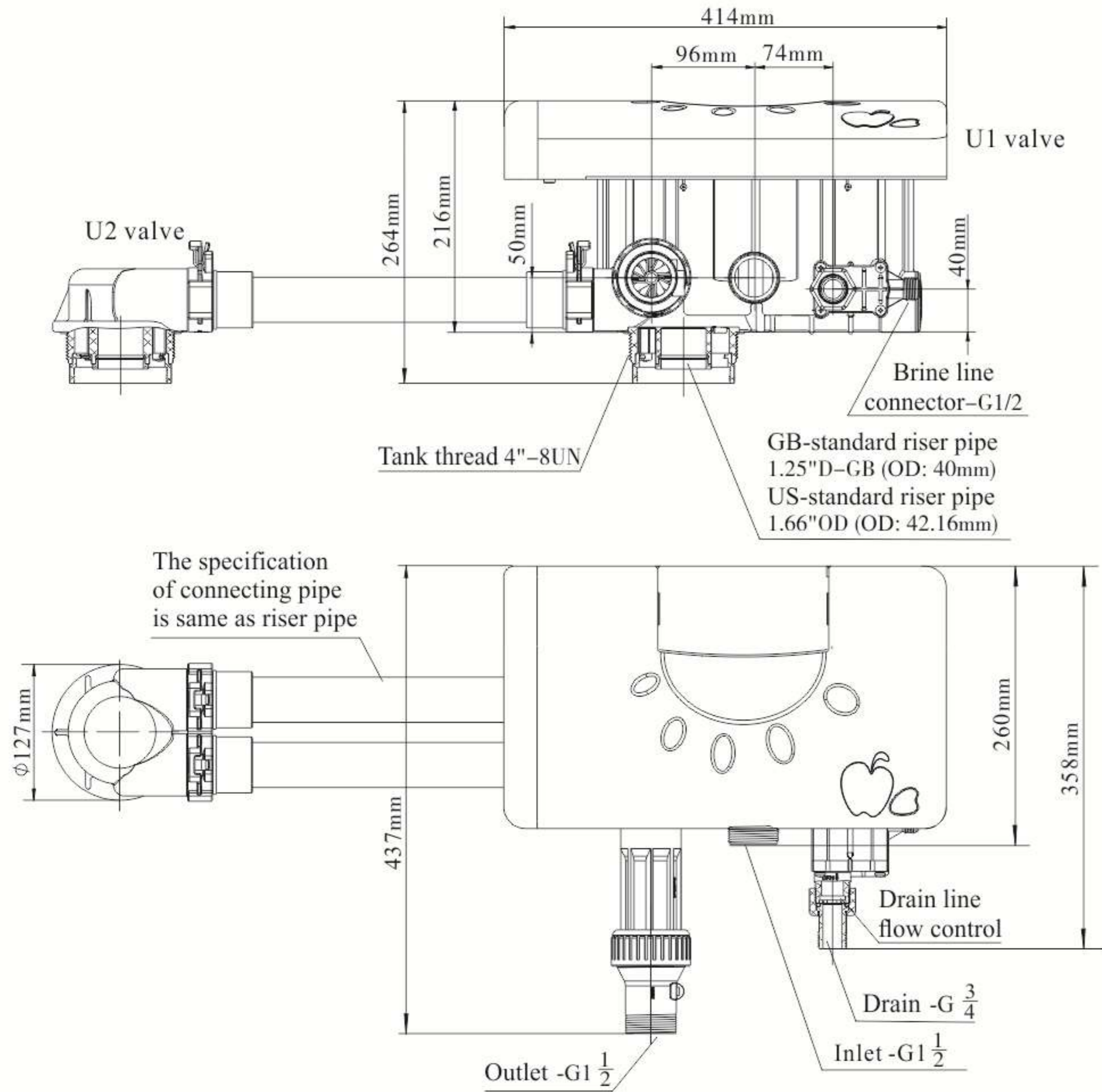

Transformer output is DC24V, 1.5A

Model	Connector size					Flow Rate m ³ /h @0.3MPa	Remark
	Inlet/outlet	Drain	Brine line connector	Base	Riser pipe		
17610T	1.5" M	3/4" M	1/2" M	4" -8UN	1.25"D-GB (OD:40mm) or 1.66"OD (OD:42.16mm)	10	Meter type Top-mount ed installation

M-Male F-Female

There are two kinds of riser pipe: GB-standard riser pipe and US-standard riser pipe. By default, the valve is equipped with GB-standard riser pipe. Please indicate it when ordering

MODEL: F135A(17610T)

if users need the valve to be equipped with US-standard riser pipe.

•This product does not include connecting pipe and riser pipe.

2.Installation

A.Installation notice

Before installation, read all those instructions completely. Then obtain all materials and tools needed for installation.

The installation of product, pipes and circuits should be accomplished by professional to ensure the product can operate normally.

Perform installation according to the relative pipeline regulations and the specification of Water Inlet, Water Outlet, Drain Outlet, Brine Line Connector.

B.Device location

- 1.The softener should be located close to drain.
- 2.Ensure the unit is installed in enough space for operating and maintenance.
- 3.Brine tank needs to be close to softener.
- 4.The unit should be kept away from the heater, and not be exposed outdoor. Sunshine or rain will cause the system damage.
- 5.Please avoid to install the system in one acid/alkaline, magnetic or strong vibration circumstance, because above factors will cause the system disorder.
- 6.Do not install the filter or softener, drain pipeline in circumstance which temperature may drop below 5°C, or above 50°C.
- 7.Install the system in the place where with the minimum loss in case of water leaking.

C.Install control valve

- 1.As the Figure 1 shows, glue the riser pipe to the bottom strainer and put it into the mineral tank, cut off the exceeding tube out of tank top opening and make external rounding.
- 2.Fill specified quantity of resin to the tank.
- 3.Screw top strainer into valve.
- 4.Insert the riser tube into control valve and screw tight control valve.
- 5.Install the U2 valve to resin tank as shown in above steps.

Notice:

•The length of riser tube should be neither higher 4mm nor lower 5mm than tank top opening height, and its top end should be rounded to avoid damage of O-ring inside the valve.

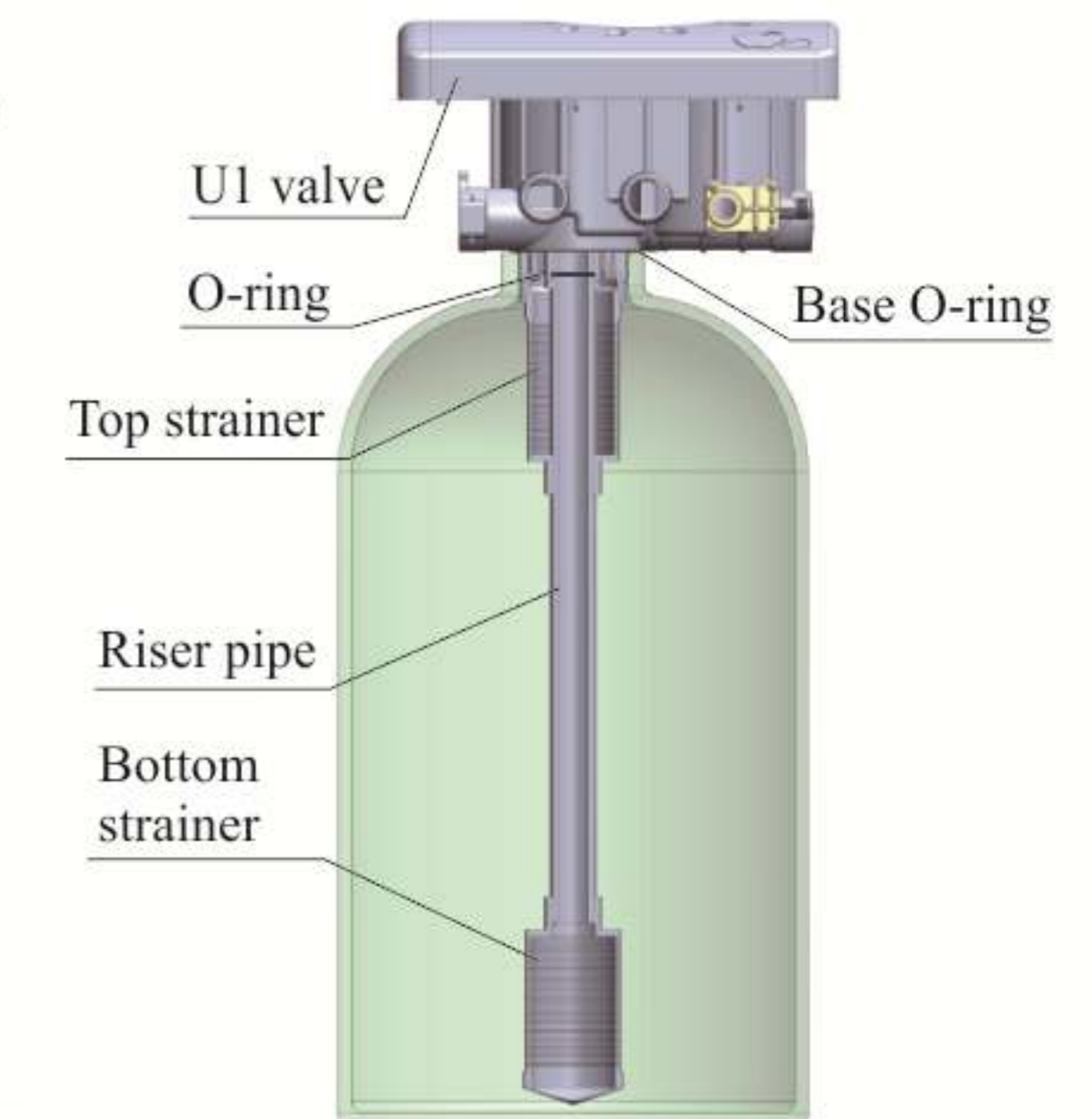

Figure 1

MODEL: F135A(17610T)

- Avoid filling floccules substance together with resin to be filled in the mineral tank.
- Avoid O-ring inside control valve falling out while rotating it on the tank.
- The height of the two resin tanks should be same.

D. Connect U1 valve with U2 valve

As Figure 2 shows:

1. Glue two ends of connecting pipes to the connector. (The connector is equipped with O-ring)
2. Insert the adhesive connecting pipe into the corresponding hole of U1 valve and fix it with clip.
3. Connect the inlet and outlet with connecting pipes, push the resin tank to load the connecting pipe into U2 valve, and fix it with the clip.

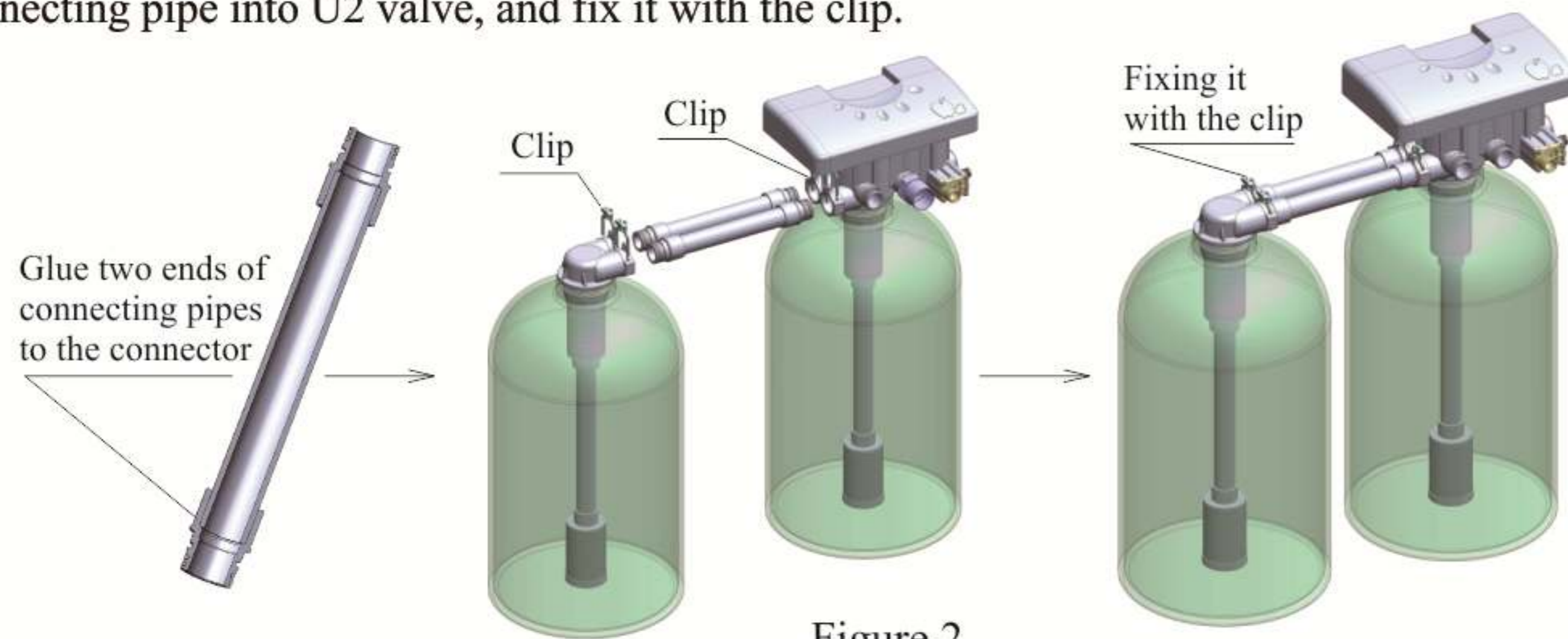

Figure 2

E. Install flow meter and drain connector

As Figure 3 shows:

1. Install the flow meter and sealing ring on outlet.
2. Insert the sensor of probe wire into flow meter.
3. Put the nut, connector, sealing ring and DLFC (if have) on drain.

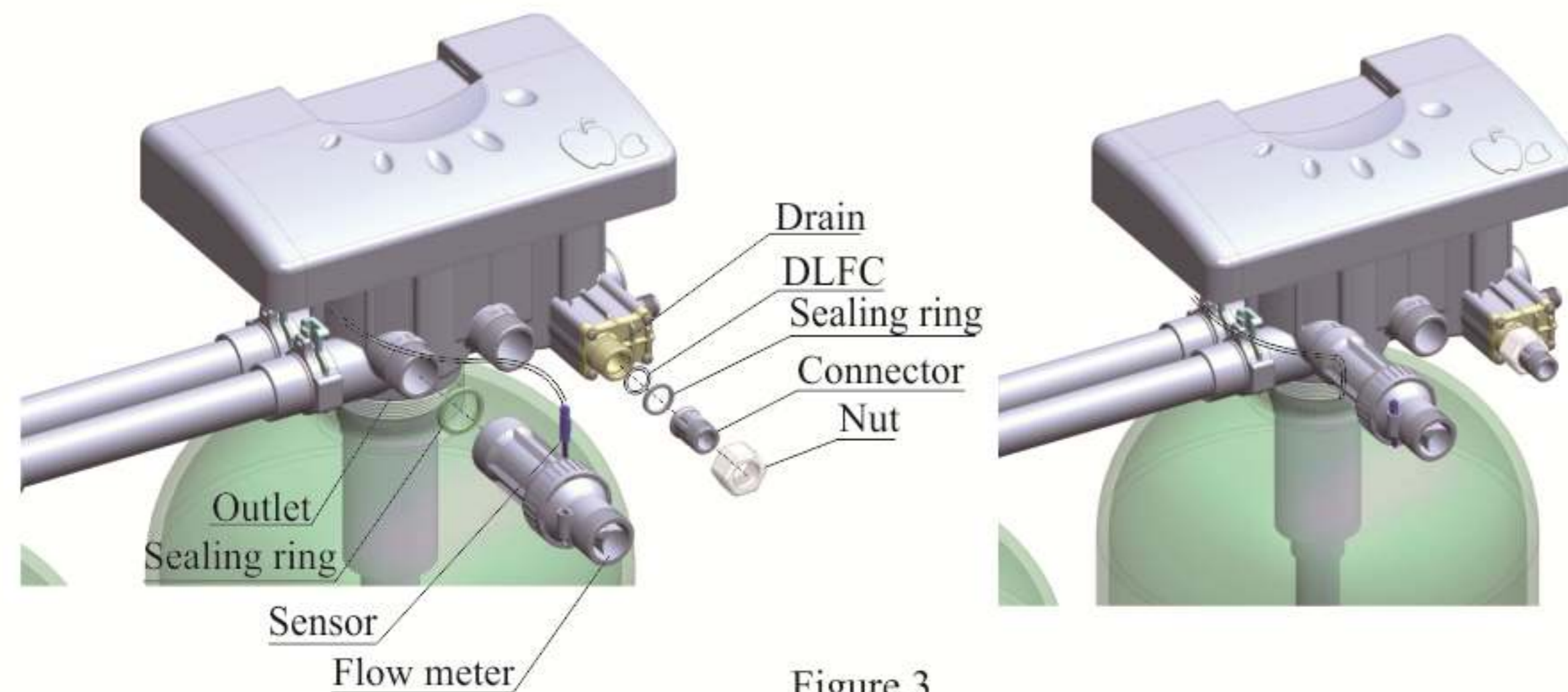

Figure 3

MODEL: F135A(17610T)

F. Pipeline connection

As Figure 4 shows (only for reference):

1. Install pressure gauge and valve C on inlet, install valve A and sampling valve on outlet.
2. Install valve B on the middle of pipeline, and fix with support.
3. Use 3/4" UPVC pipe as drain pipeline and 1/2" UPVC pipe as brine pipeline.

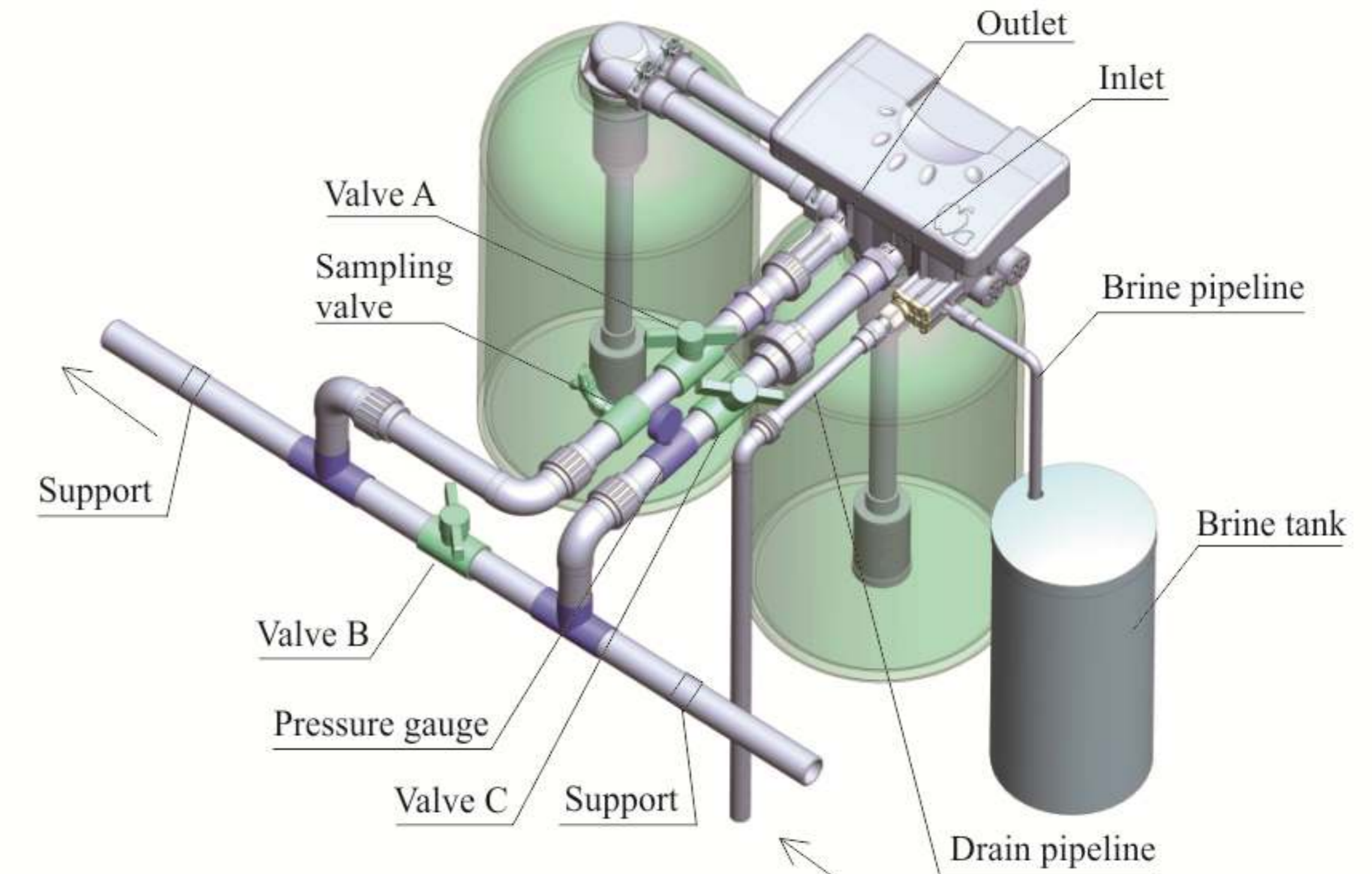

Figure 4

Notice:

- Control valve should be higher than drain outlet, and be better not far from the drain hose.
- Be sure not connect drain with sewer directly, and leave a certain space between them, to avoid wastewater being absorbed to the water treatment equipment.
- Brine pipeline should be as short and smooth as possible. There should be no more than four elbows on the brine pipeline to prevent poor salt absorption.
- There must be brine valve installed in brine tank.

MODEL: F135A(17610T)

3.System Configuration and Flow Rate Curve

A.Product Configuration

Product configuration with tank, resin volume, brine tank and injector:

Tank Size (mm)	Resin Volume (L)	Flow Rate (t/h)	Brine Tank Size (mm)	The Minimum Salt Consumption for Regeneration (Kg)	Injector Model
φ500×1800	200	5.0	φ740×1275	30.00	2#
φ600×1800	300	7.0	φ740×1275	45.00	3#
φ750×1800	450	11.0	φ840×1335	67.50	4#

Attention: The flow rate calculation is based on linear velocity 25m/h; the minimum salt consumption for regeneration calculation is based on salt consumption 150g / L (Resin).

B.Flow Rate Characteristic

1).Pressure flow rate curve

17610T:

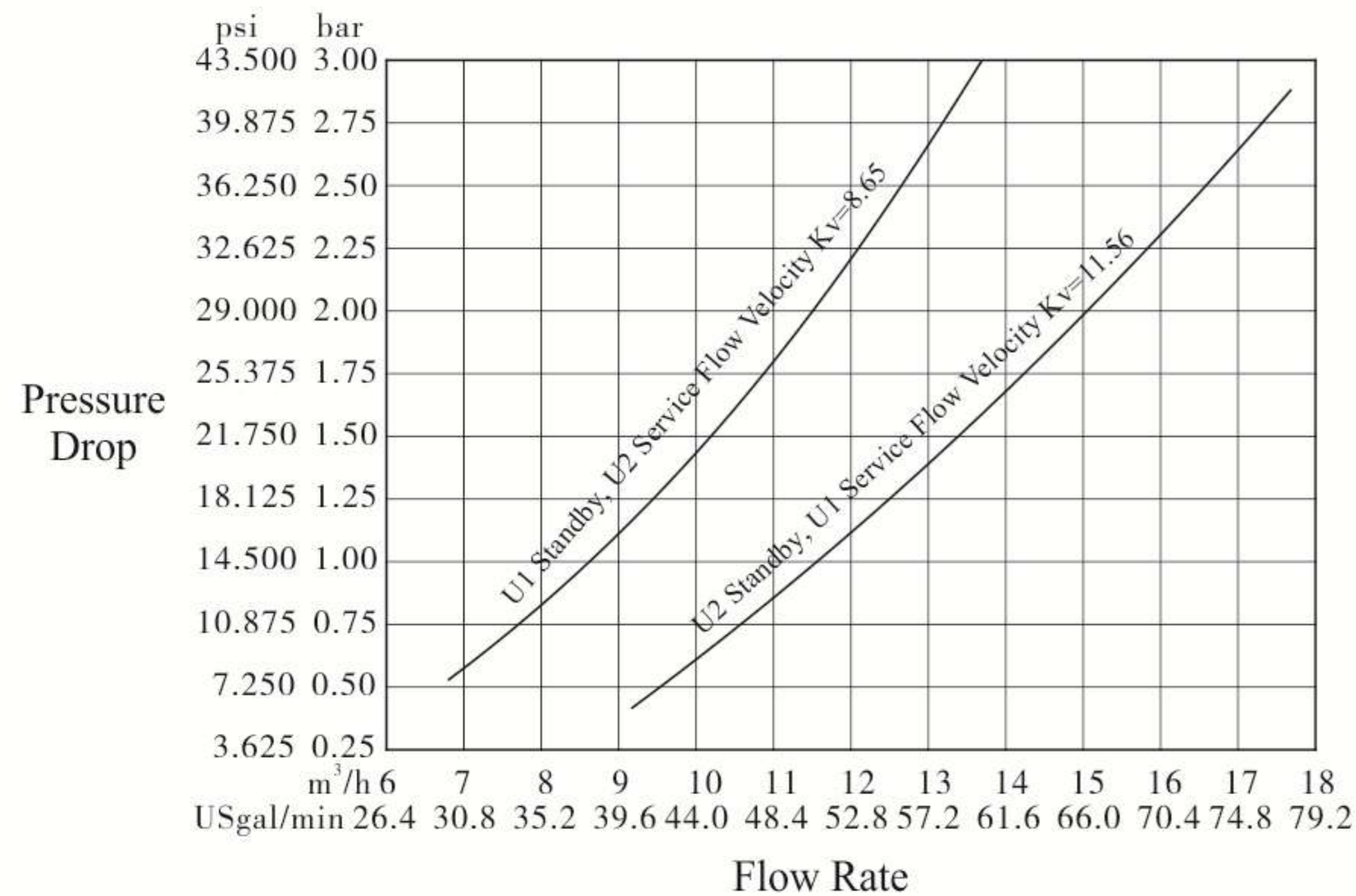

MODEL: F135A(17610T)

2).Injector parameter table

Inlet Pressure	Draw Rate (L/M)		
	2#	3#	4#
MPa			
0.15	11.20	17.55	25.20
0.20	13.05	19.90	29.45
0.25	14.70	22.35	32.85
0.30	16.35	24.75	36.05
0.35	17.60	26.90	39.85
0.40	18.55	28.35	42.05

3).Configuration for Standard Injector and Drain Line Flow Control

Tank Dia. mm	Injector Model	Injector Color	Draw Rate	Slow Rinse	Brine Refill	DLFC	Backwash / Fast Rinse
			L/m	L/m	L/m		L/m
500	2#	Pink	16.35	9.85	28.40	8468008	58.33
600	3#	Yellow	24.75	18.29	44.74	8468009	72.50
750	4#	Blue	36.05	27.45	57.20	Without DLFC	80.33

Remark: Above data for the product configuration and relevant characteristics are only for reference. When put in practice, please subject to the different requirements of raw water hardness and application.

• Above data is tested under 0.3MPa raw water inlet water pressure.

4.Basic Setting & Usage

Please refer to 0WRX.466.539 user manual for more details.

MODEL: F135A(17610T)

5.Assembly & Parts

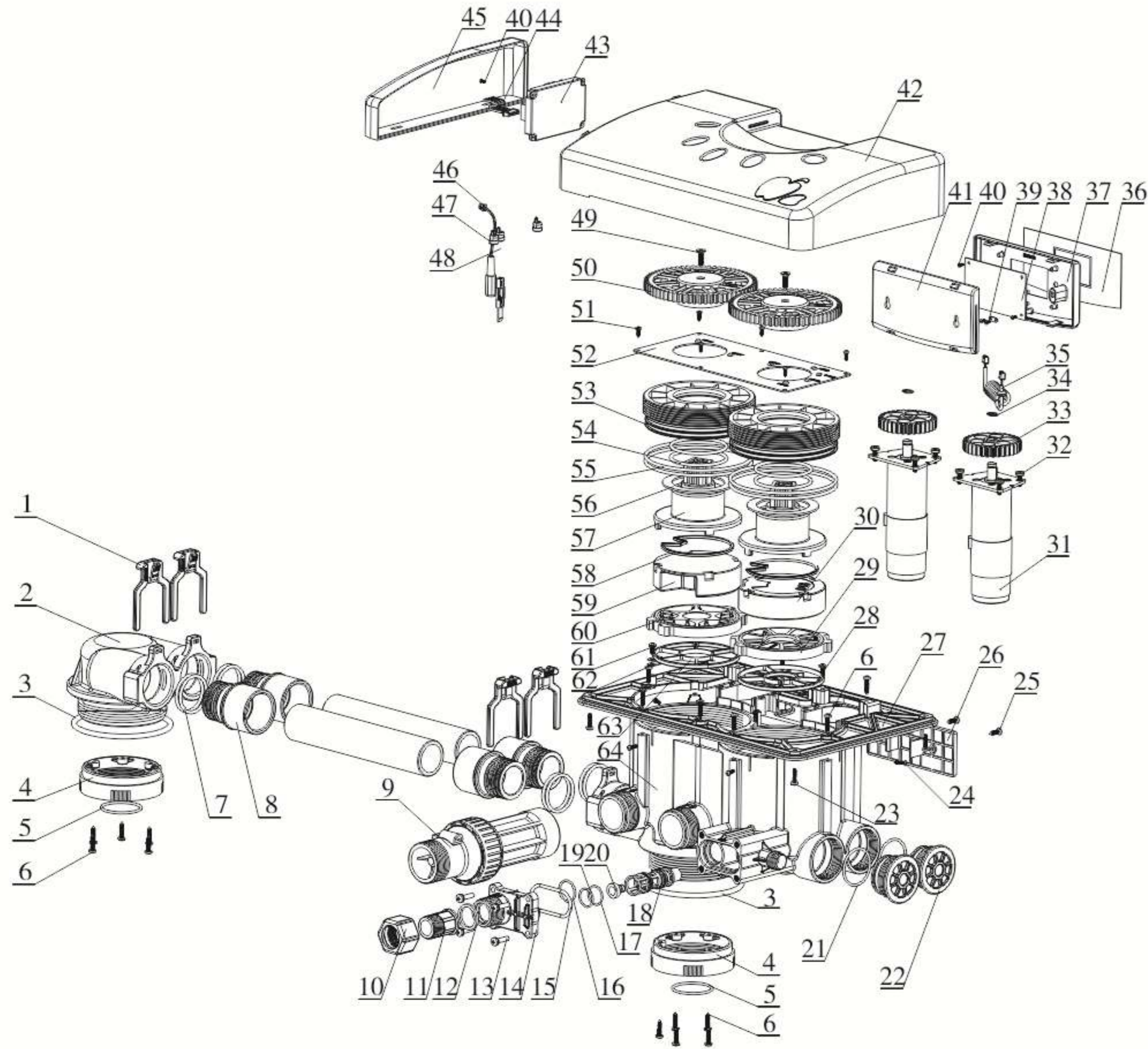

Component and part No. for 17610T:

Item No.	Description	Part No.	Quantity
1	Clip	8270031	4
2	Valve Body	5022204	1
3	O-ring $\phi 104.6 \times 5.7$	8378146	2
4	Connector	8458018	2
5	O-ring 40×2.65	8378091	2
6	Screw, Cross ST 3.9×19	8909003	19
7	O-ring 38.7×3.55	8378184	8

MODEL: F135A(17610T)

Item No.	Description	Part No.	Quantity
8	Joint	8458294	4
9	Flow Meter	5447010	1
10	Animated Connector	8945043	2
11	Joint	8458219	1
12	Sealing Ring	8371053	1
13	Screw, Cross M5 $\times 20$	8902064	4
14	Cover, Injector	8315159	1
15	O-ring 45×3.55	8378312	1
16	O-ring 22×2.2	8378351	1
17	O-ring 19×1.8	8378021	1
18	Throat, Injector	Optional	1
19	O-ring 20×1.8	8378024	1
20	Nozzle, Injector	Optional	1
21	O-ring 40×2.65	8378091	2
22	Plug	8323009	2
23	Screw, Cross ST 3.9×16	8909044	4
24	Screw, Cross ST 2.9×13	8909023	4
25	Screw, Cross ST 3.9×16	8909014	2
26	Display Holder	8040003	1
27	Connecting Board	8152112	1
28	Sealing Ring	8370153	1
29	Fixed Disk	8469045	1
30	Moving Disk	8459048	1
31	Motor	6158039	2
32	Screw, Cross ST 3.9×16	8909044	8
33	Small Gear	5241008	2
34	Pin	8994009	2
35	Three-core Spring	5517001	1
36	Sticker	8865011	1
37	Display Cover	8300013	1
38	Display Board	6381007	1
39	Wire Clip	8126001	1
40	Screw, Cross ST 2.2×6.5	8909004	2

MODEL: F135A(17610T)

Item No.	Description	Part No.	Quantity
41	Display Cover	8315008	1
42	Dust Cover	8005029	1
43	Control Board	6382019	1
44	Wire for Locating Board	5511010	1
45	Front Cover	8300028	1
46	Wire for Power	5513001	1
47	Wire Clip	8126004	3
48	Probe Wire	6386001	1
49	Shell, Flow Meter	5002004	1
50	Big Gear	5241025	2
51	Screw, Cross ST 2.9×9.5	8909008	6
52	Locating Board	6380079	1
53	Fitting Nut	8092032	2
54	O-ring 59.92×3.53	8378110	4
55	O-ring 117.6×3.55	8378133	4
56	Anti-friction Washer	8216006	2
57	Shaft	8258005	2
58	Moving Seal Ring	8378018	2
59	Moving Disk	8459047	1
60	Fixed Disk	8469044	1
61	Screw, Cross ST 3.9×13	8909013	1
62	Wire Clip	8126002	1
63	Seal Ring	8370071	1
64	Valve Body	5022180	1

Remark: It is GB- standard for item No.2, 5, 8, and 64. The US-standard for item No.2 is 5022204A, for item No.5 is 8378325, for item No.8 is 8458298 and for item No.64 is 5022180A.

MODEL: F135A(17610T)

6. Warranty Card

Dear client:

This warranty card is the guarantee proof of RUNXIN brand multi-functional flow control valve. It is kept by client self. You could get the after-sales services from the supplier which is appointed by RUNXIN manufacturer. Please keep it properly. It couldn't be retrieved if lost. It couldn't be repaired free of charge under the below conditions:

1. Guarantee period expired.(One year);
2. Damage resulting from using, maintenance, and keeping that are not in accordance with the instruction;
3. Damage resulting from repairing not by the appointed maintenance personnel;
4. Content in guarantee proof is unconfirmed with the label on the real good or be altered;
5. Damage resulting from force majeure.

Product Name	 Multi-functional Flow Control Valve for Water Treatment Systems		
Model		Code of Valve Body	
Purchase Company Name		Tel/Cel.	
Problem			
Solution			
Date of Repairing		Date of Accomplishment	Maintenance Man Signature

When product needs warranty service, please fill in the below content and send this card together with the product to the appointed suppliers or Runxin company.

End-user Company Name		Tel/Cel.	
Purchase Company Name		Tel/Cel.	
Model		Code of Valve Body	
Tank Size ϕ ×		Resin Tank Size L	Raw Water Hardness mmol/L
Water Source: Ground-water <input type="checkbox"/> Tap Water <input type="checkbox"/>		Water Treatment Capacity m ³	Backwash Time min
Brine & Slow Rinse Time min		Brine Refill Time min	Fast Rinse Time min
Problem Description			